



OEM Tank Hanger Instructions

12-380 | 1963-67 Corvette

Tools Needed: Philips Head Screw Driver & In-Lb Torque Wrench

1. Install supplied HydraMat onto the pump using the alignment dowel to locate. Press firmly to seat.
2. Remove the two screws holding the fuel level sender onto the assembly.

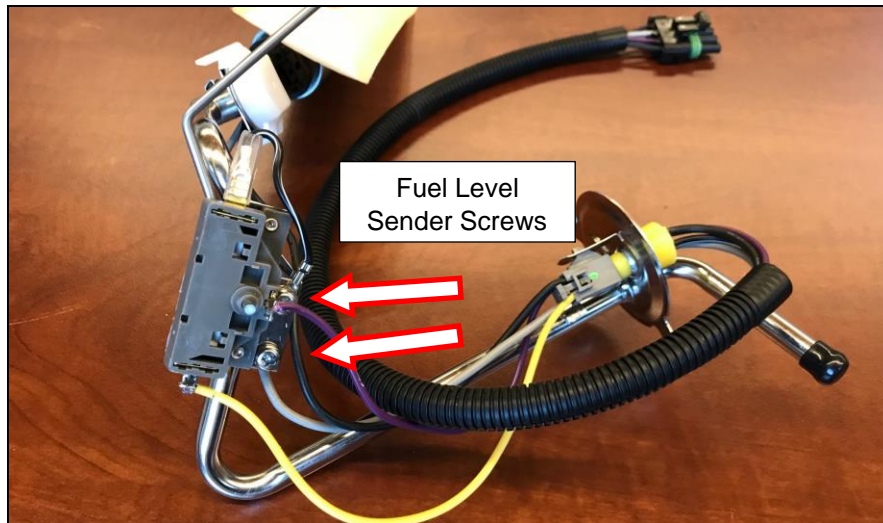

Figure 1

3. Insert the HydraMat and Pump assembly into the tank leaving the fuel level sender exposed. Be sure to insert the long end of the HydraMat into the tank first when you get to the two screw holes for the level sender, then insert the sender into the tank starting with the float and secure with mounting screws. Torque to 23 ± 3 in-lbs.

NOTE: Be sure not to tear the HydraMat as it is being inserted into the tank.

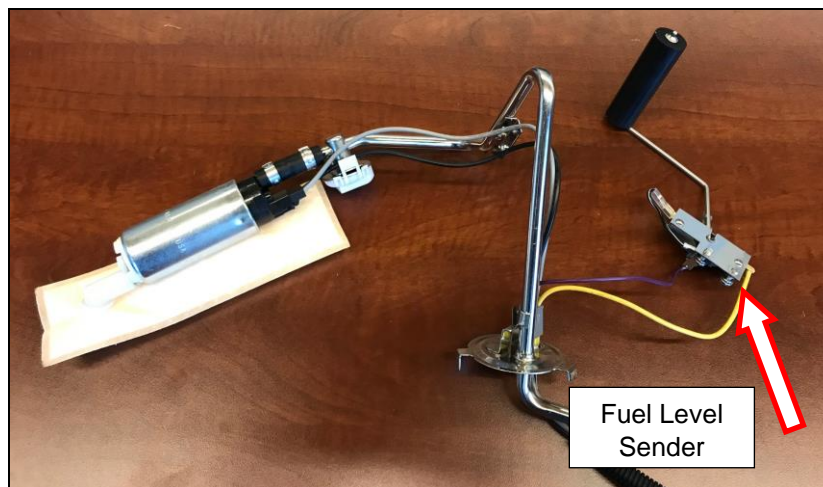

Figure 2



Figure 3



Figure 4

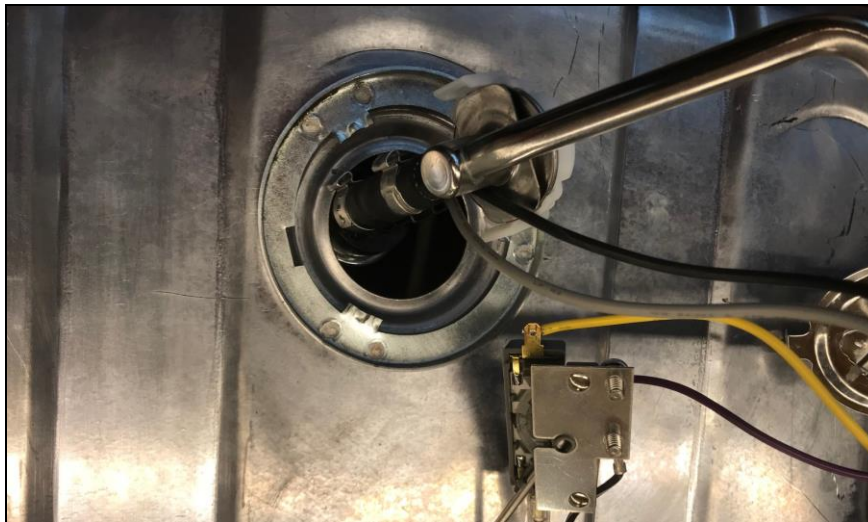

Figure 5



Figure 6

4. Run the supplied O-ring gasket over the supply tube and wires and stretch around the bulkhead plate (**Figure 7**).



Figure 7

5. Seat bulkhead plate on gasket and secure with locking ring (**Figure 8**).



Figure 8

WIRING:

WARNING! USE A MINIMUM OF 12 GAUGE WIRE. BE SURE TO CRIMP OR SOLDER ALL CONNECTORS SECURELY AND CLEAN ANY AREA WHERE GROUND LEADS WILL BE FASTENED. FAILURE TO USE THE MINIMUM WIRE GAUGE COULD RESULT IN PUMP MALFUNCTION AND/OR ELECTRICAL FIRE, RESULTING IN PROPERTY DAMAGE, SERIOUS INJURY, AND/OR DEATH.

1. Disconnect the cables from the battery.
2. Mount relay/relays in convenient location away from exhaust heat.
3. A 20A fuse must be run between the red wire that runs between the battery and the relay harness.

NOTE: Wire colors correspond to Holley P/N 12-753. The 12-753 comes with a 15A fuse. The 20A fuse must be purchased separately.

4. Plug the fuel pump relay harness into the relay, until it locks into place.
5. Connect the black wire of the harness to ground.

NOTE: Be sure to route all electrical wires clear of any moving suspension or drivetrain components and any exhaust components! Protect wires from abrasion and road obstructions or debris.

WARNING! IT IS IMPERATIVE THAT A 20A FUSE BE INSTALLED ON THE WIRE THAT GOES BETWEEN THE RELAY WIRING HARNESS AND THE BATTERY. FAILURE TO INSTALL THIS 20A FUSE COULD RESULT IN A PUMP MALFUNCTION AND/OR ELECTRICAL FIRE, RESULTING IN PROPERTY DAMAGE, SERIOUS INJURY, AND/OR DEATH.

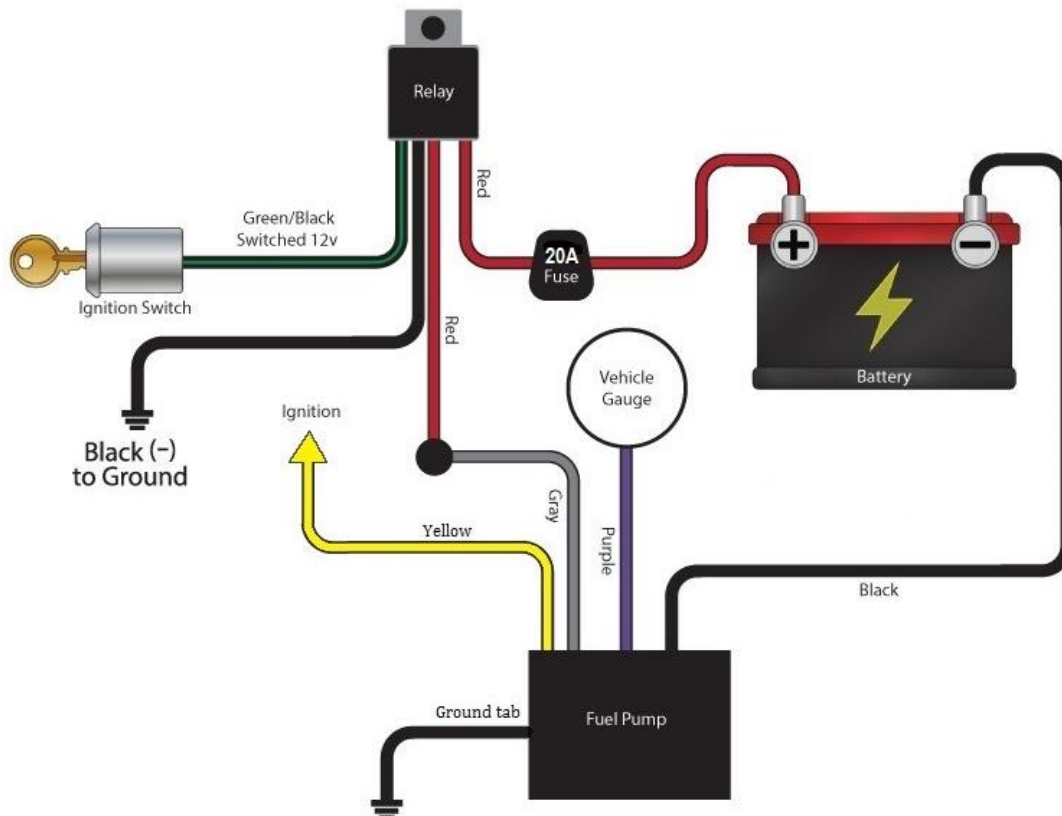

Plumbing Note:

If connecting to factory vehicle fuel hard lines, make sure that any rubber hose and clamps used are rated for EFI pressures.

Technical Support: 1-866-464-6553

199R12277

Revision Date: 1-5-22