



Installation Instructions

615142

2007-11 JEEP WRANGLER

3.8L ENGINE

This kit is not designed to fit vehicles with a body lift.

THIS INTAKE SYSTEM IS 50-STATE LEGAL FOR THE VEHICLES LISTED ABOVE PER CARB EXECUTIVE ORDER D-698-10. SEE WWW.FLOWMASTERMUFFLERS.COM FOR CARB STATUS OF INTAKE SYSTEMS FOR OTHER VEHICLES.



Watch our installation video on YouTube

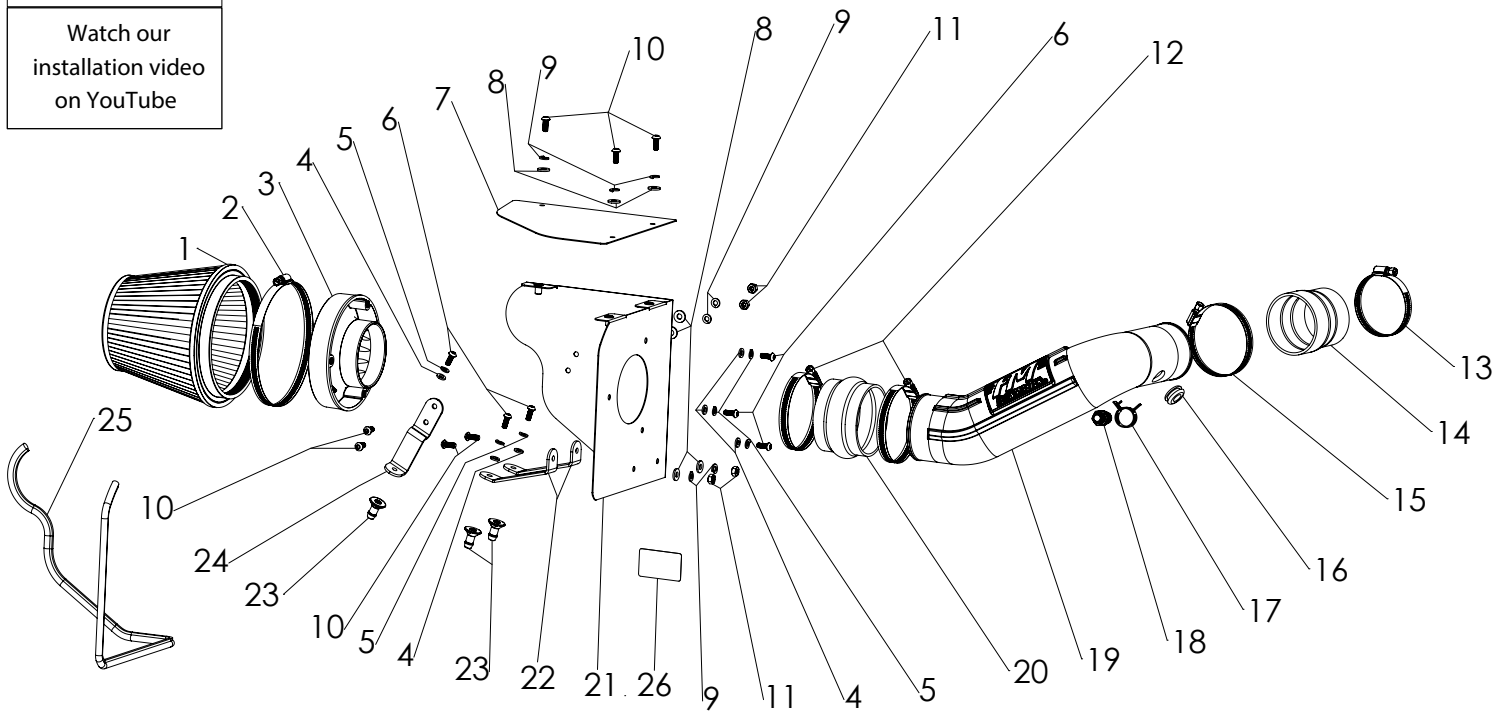

ITEM NO.	PART NUMBER	DESCRIPTION	QTY.
1		AIR FILTER, 6-5/8" x 6" DIA	1
2	AF1003	SCREW CLAMP, #104 (4-1/8" - 7")	1
3	AF6001	ADAPTER, AIR FILTER 3-1/2" x 6"	1
4	HW319	FLAT WASHER, M6	6
5	HW318	LOCK WASHER, M6	6
6	HW244	SCREW, M6 x 1.0 x 16MM	6
7	AF3013	LID, AIRBOX	1
8	HW320	FLAT WASHER, 1/4"	7
9	HW322	LOCK WASHER, 1/4"	7
10	HW245	SCREW, 1/4"-20 x 5/8"	7
11	HW115	NUT, 1/4"-20	4
12	MC350H	SCREW CLAMP, #56 (3-1/16" - 4")	2
13	MC250H	SCREW CLAMP, #44 (2-1/4" - 3-1/4")	1
14	AF4031	COUPLER, REDUCING 3" - 2-3/4" I.D. x 3" L	1

ITEM NO.	PART NUMBER	DESCRIPTION	QTY.
15	MC314H	SCREW CLAMP, #52 (2-13/16" - 3-3/4")	1
16	AF4008	GROMMET, 1-1/16" OD x 1/2" ID x 7/16" THK	1
17	MC004P	PINCH CLAMP, 5/8" HOSE	1
18	AF4032	FITTING, STRAIGHT 5/8" BARB TO 1/4" NPT MALE	1
19	AF2013	INTAKE TUBE	1
20	AF4019	COUPLER, FLEX 3-1/2" I.D. x 2-1/2" L	1
21	AF3007	HEAT SHIELD	1
22	AF5015	11GA X 1" BRACKET #2	2
23	AF7001	BARBED PIN, M6 x 1.0	3
24	AF5014	11GA X 1" BRACKET #1	1
25	49000061	GASKET, HEAT SHIELD	1
26	D-698-10	EXECUTIVE ORDER DECAL	1

REVIEW THE INSTRUCTIONS AND VERIFY KIT CONTENTS:

1. Please take a moment to read and understand these instructions before installing your Flowmaster cold air intake kit.



2. Use the parts drawing and list (front page) to verify your kit's contents.

In the unlikely event that any parts are missing, please contact FLOWMASTER Technical Support for replacements.

To simplify assembly and avoid cross-threading fasteners, identify and separate the 1/4-20 screws, item (10) (used with nuts (11) and airbox (21)), and the M6 screws, item (6) (used with barbed pins (23) and filter adapter (3)).

REMOVE FACTORY AIR INTAKE SYSTEM:

NOTES

- We highly recommend that you retain all factory air intake system parts.
- Please refer to vehicle manufacturer's recommendations regarding removal of factory components.
- Disconnecting the negative battery cable erases pre-programmed electronic memories. Write down all memory settings before disconnecting the negative battery cable. Some radios will require an anti-theft code to be entered after the battery is reconnected. The anti-theft code is typically supplied with your owner's manual. In the event your vehicle's anti-theft code cannot be recovered, contact an authorized dealership to obtain your vehicle's anti-theft code.

3. Turn off the vehicle's ignition and disconnect the negative battery cable.



4. Carefully remove intake air temperature sensor electrical connector by pulling the locking tab out until it stops, then depressing the latch and pulling the connector straight off the sensor.



5. Disconnect PCV hose from airbox.

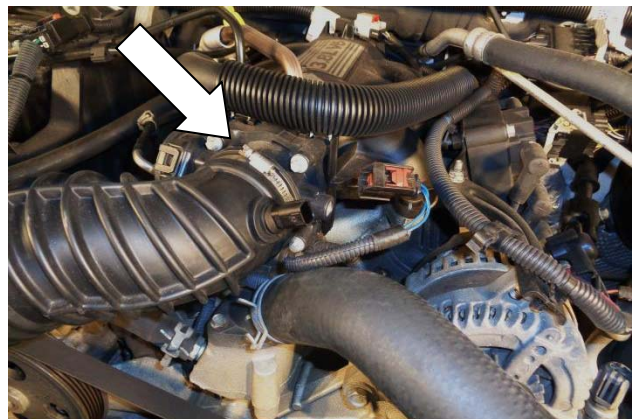

6. Loosen hose clamp securing the air intake duct to the throttle body.



7. The airbox is retained by three barbed pins. Pull the intake duct free of the throttle body, then grasp the airbox and lift the assembled airbox and duct straight up.

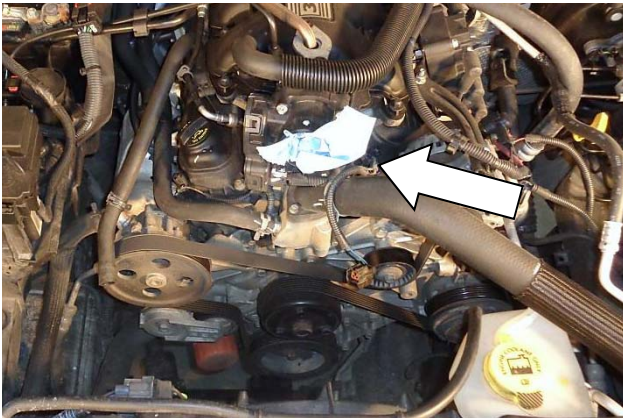

8. Protect the throttle body opening from foreign objects by **temporarily** inserting a clean rag or paper towel in the opening, or securing a plastic bag over the opening with a rubber band. (**To be removed at Step 19.**)



9. The intake air temperature sensor is held in the intake duct by friction. Firmly grasp it and, while pulling it away from the duct, carefully wiggle it around in the duct. **CAUTION: The sensor is delicate!** Handle with care, and store in a safe location until reinstallation.

ASSEMBLE AND INSTALL YOUR FLOWMASTER COLD AIR INTAKE SYSTEM:



10. Attach 1 bracket (24) and 2 brackets (22) to airbox (21) using ¼-20 screws (10) (on the bracket side), and flat washers (8), lock washers (9) and nuts (11) (on the airbox side).



11. Attach the rubber trim seal (25) to the airbox. Starting at either corner, firmly press the seal onto the edge, gradually working around the airbox. At the other corner, trim the seal to fit using metal-cutting shears.



12. Attach barbed pins (23) to brackets using M6 screws (6), lock washers (5), and flat washers (4).

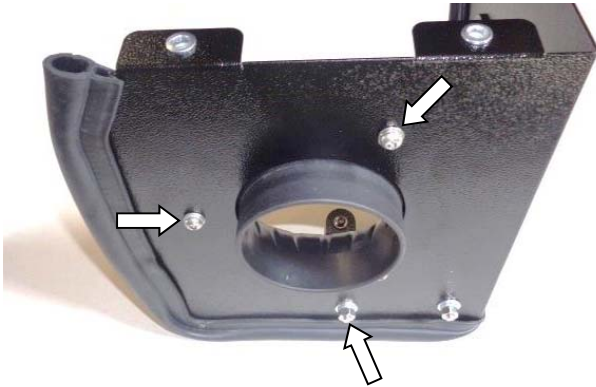

13. Assemble air filter adapter (3) to airbox using M6 screws (6), lock washers (5) and flat washers (4).



14. Set assembled airbox in vehicle, aligning the 3 barbed pins with their rubber grommets in the vehicle. Adjust alignment of brackets (22) if required. Push each pin into its grommet, one at a time. **NOTE:** Moistening the grommets with soapy water will ease insertion.



15. Apply 2 wraps of nylon thread tape to threads of barbed PCV fitting (18), and install fitting in intake tube (19). Install rubber grommet (16) in intake tube.



16. Carefully insert the intake air temperature sensor into the grommet, ensuring that the notch in its base points downstream. **NOTE:** Moistening the grommet with soapy water will ease insertion.



17. Install 2 hose clamps (12) on flex coupler (20), and install coupler on intake end of intake tube. Install hose clamps (15) and (13) on tapered coupler (14), and install coupler on discharge end of tube. Orient clamp screws so as to allow tightening after installation on vehicle.

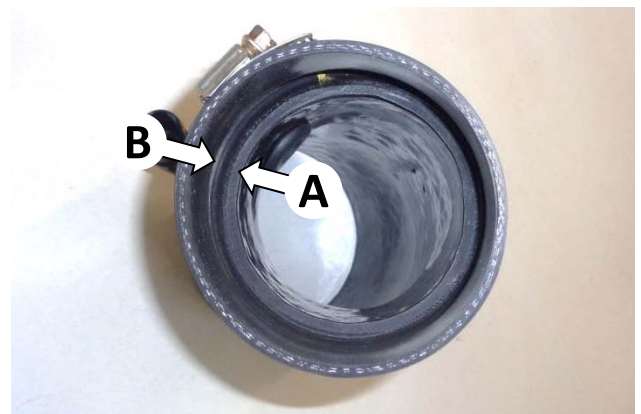

18. To allow proper flexing of the flex coupler during engine torqueing, verify that the end of the intake tube (A) sits even with, or slightly behind, the coupler's transition lip (B).



19. Remove the rag or plastic bag (temporarily installed at Step 8) from the throttle body opening. Install assembled intake tube in vehicle and tighten all hose clamps.



20. Secure PCV hose on barbed fitting with pinch clamp (17).



21. Reinstall the intake air temperature sensor connector and verify the connector is secure.



22. Install clamp (2) on air filter (1), install filter on filter adapter and tighten clamp.



23. Install airbox cover (7) on airbox, using ¼-20 screws (10), lock washers (9), and flat washers (8).

FLOWMASTER CARB EO #
THE PERFORMANCE TECHNOLOGY COMPANY™

DELTA FORCE PERFORMANCE INTAKE

D-698-10

FLOWMASTER INC. • 866-464-6553
1801 RUSSELLVILLE ROAD, BOWLING GREEN, KY 42101

24. Affix the CARB Exemption Order label to a clean, readily-visible location under the hood (e.g., near the hood latch), so an inspector can easily see it at emissions testing.



Congratulations, the installation of your FLOWMASTER cold air intake kit is now complete!

