



FORCE II

Installation Instructions
817651
2011-22 DODGE DURANGO RT
3.6L & 5.7L ENGINE
2/4 Wheel Drive

OVERVIEW:

1. Take a moment to read and understand these instructions before installing your Flowmaster performance system.

NOTE: Please inventory all parts now before continuing and if necessary, report any missing items to our tech line. This will avoid potentially stranding your vehicle until any missing replacement parts arrive.

ITM #	PART #	DESCRIPTION	QTY.
1	15175S	Right Resonator Assembly	1
2	15176S	Left Resonator Assembly	1
3	16732S	Scavenger Assembly	1
4	852562-254	Left Muffler Assembly	1
5	852562-255	Right Muffler Assembly	1

ITM #	PART #	DESCRIPTION	QTY.
N/A	PK728	Hardware Package includes:	1
6	453HA	Front Frame Hanger	2
7	MC250BS	2½" Stainless Band Clamp	4
8	HW213	M10-1.5 x 60mm Bolt	4
9	HW506	¾" x 1½" Steel Spacer	4
10	HA168	Rubber Hanger	2
11	HW502	¾" Hanger Keepers	8
12	HW303	¾" Flat Washers	4

REMOVE STOCK EXHAUST SYSTEM:

2. Raise vehicle up on a hoist or rack to working height. If you don't have access to a hoist or rack, support vehicle with jack stands.

WARNING: Avoid serious burns! Allow your vehicle time to cool completely before touching any factory engine components.

To ease preparation and installation of your new kit:

- Apply penetrating lubricant to mounts, bolts and clamps before you remove them.
- Use stands as necessary to support parts as you detach them from your vehicle and again as you install new parts.

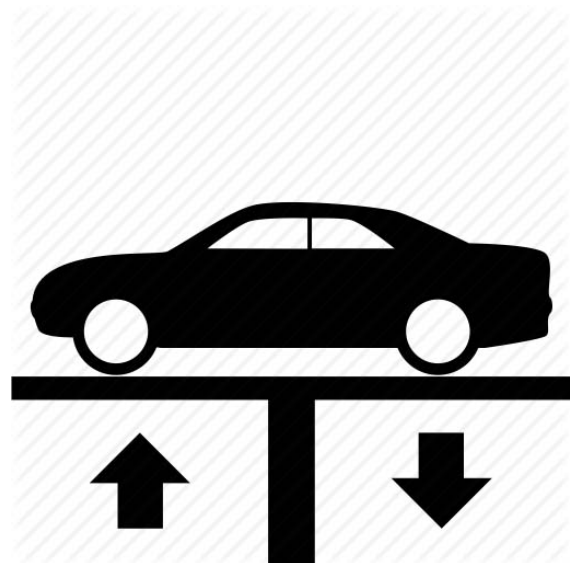

3. Remove fasteners and disconnect exhaust at front flange connections (x2). Retain (x4 ea.) springs and nuts then disconnect wire hangers. Remove and retain bolts (x4) from mounts then lower system down and set it aside.



INSTALL FLOWMASTER EXHAUST SYSTEM

4. Remove nuts from stock and Flowmaster clamps, apply anti-seize compound to bolts and re-install nuts.

NOTE: The image in this step is intended for illustrative purposes only and may or may not accurately reflect components included in your kit.



5. Replace mounts using (x2) **front frame hangers (6)** and (x4) bolts (removed step 3). Then install (x2) **rubber hangers (10)** onto front frame hangers.

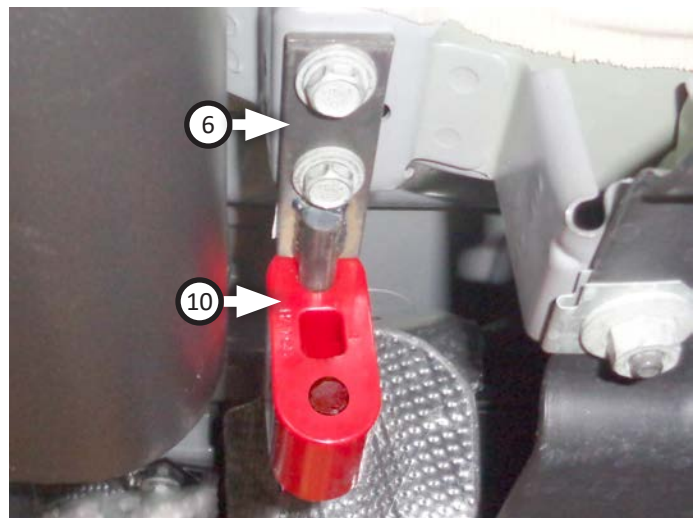
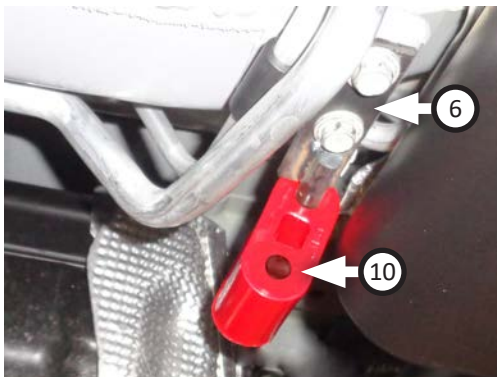

6. Place (x2) **clamps (7)** onto front of **scavenger assembly (3)** then connect it to **right (1)** and **left (2)** resonator. Hang assembly (with center Flowmaster logo facing ground) by inserting wire hangers into rubber hangers.

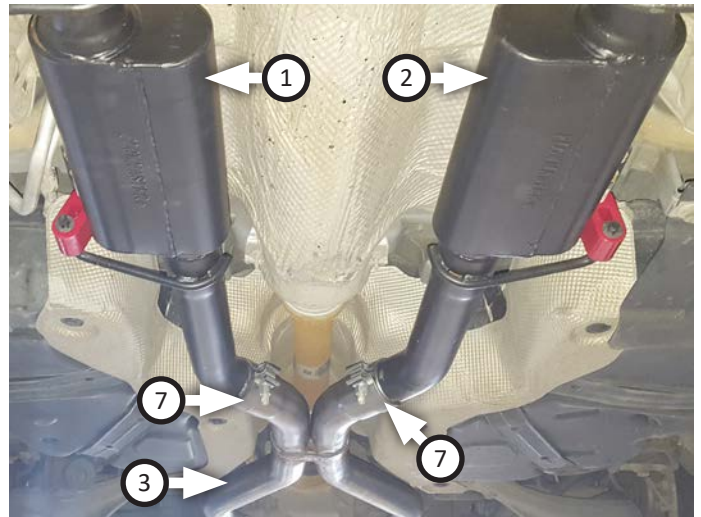

7. Use (x2 ea.) **bolts (8)**, **steel spacers (9)**, **flat washers (12)**, springs and nuts (removed step 3) to fasten right and left resonators to factory flanges then tighten clamps enough to allow for later adjustment.

NOTE: Tighten fasteners until nuts bottom out on steel spacer sleeves.



8. Place **clamp (7)** onto **left muffler assembly (4)**, connect it to left side scavenger outlet, insert wire hangers into isolators then tighten clamp enough to hold parts. Repeat step with **right muffler assembly (5)**.

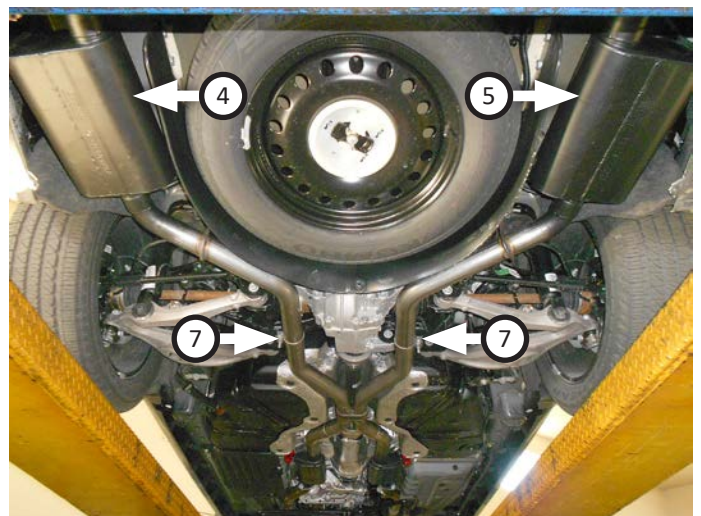

9. Adjust exhaust components for fit; maintaining ½" clearance and compensating for suspension, travel and vibration, then tighten all clamps. Finally, fit (x8) **hanger keepers (11)** onto each sideways hanger.
10. Recommended: Secure slip-fit connections with a 1-inch tack weld then spray high-temp paint over each weld to prevent rust and premature corrosion.

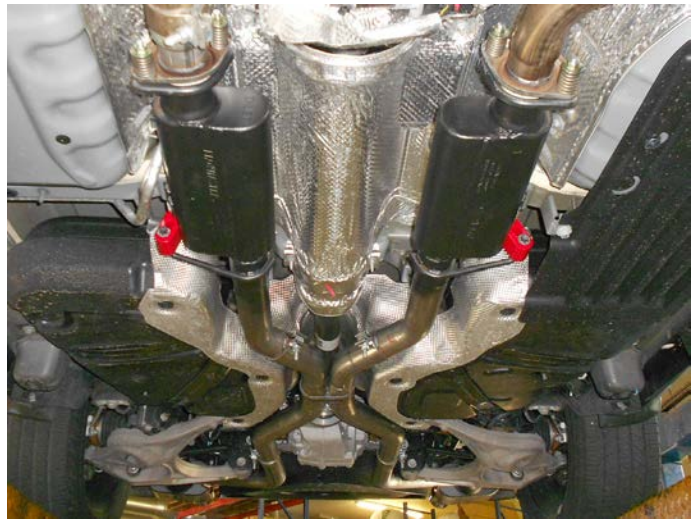

Congratulations, the installation of your FLOWMASTER performance exhaust system is now complete!





Installation Diagram
817651
2011-22 DODGE DURANGO RT
3.6L & 5.7L ENGINE
2/4 Wheel Drive

FORCE II

